

# OWNER'S GUIDE &

# INSTALLATION INSTRUCTIONS

## Tilted Element™ Transducer without Valve

Models: B60-12°, B60-20°, B619-12°, B619-20°  
P19-12°, P19-20°, SS60-12°, SS60-20°  
SS565-12°, SS565-20°, SS619-12°, SS619-20°

03/10  
17-364-01 rev. 04

**WARNING:** Always wear safety goggles and a dust mask when installing to avoid personal injury.

**CAUTION:** Never install a metal transducer on a vessel with a positive ground system.

**CAUTION:** Never use solvents. Cleaners, fuel, sealants, paint, and other products may contain strong solvents, such as acetone, which attack many plastics, greatly reducing their strength.

**IMPORTANT:** Read the instructions completely before proceeding with the installation. These instructions supersede any other instructions in your instrument manual if they differ.

### Applications

- **Plastic** housing recommended for fiberglass or metal hulls only. *Never install a plastic housing in a wood hull since swelling of the wood can fracture the plastic.*
- **Bronze** housing recommended for fiberglass or wood hulls. *Never install a bronze housing in a metal hull, because electrolytic corrosion will occur.*
- **Stainless steel** housing compatible with all hull materials. Recommended for metal hulls to prevent electrolytic corrosion *provided the stainless steel housing is isolated from the metal hull.*
- **Be sure your transducer model matches the deadrise angle** of your boat at the mounting location. See the top of the transducer for the tilt angle (see Figure 1).
  - 12° model for deadrise angles from 8° to 15°
  - 20° model for deadrise angles from 16° to 24°

To measure the deadrise angle of your hull at the selected mounting location, use an angle finder or a digital level (see Figure 2).

### Identify Your Model

The model name is printed on the cable tag.

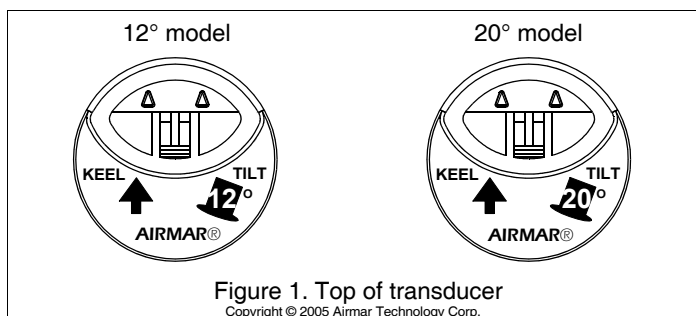

Record the information found on the cable tag for future reference.

Part No. \_\_\_\_\_ Date \_\_\_\_\_ Frequency \_\_\_\_\_ kHz

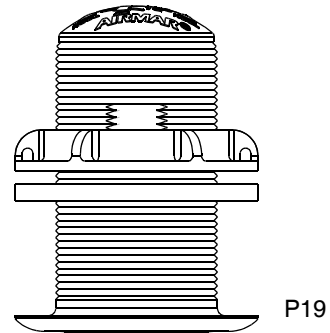

### Tools & Materials

- Safety goggles
- Dust mask
- Electric drill with 10mm (3/8") or larger chuck capacity
- Drill bit: 3mm or 1/8"
- Hole saw (see table below)
- Countersink tool (installing SS565-12° or SS565-20°)
- Sandpaper
- Mild household detergent *or* weak solvent (such as alcohol)
- File (installation in a metal hull)
- Marine sealant (suitable for below waterline)
- Slip-joint pliers (installing a metal housing)
- Grommet(s) (some installations)
- Cable ties
- Water-based anti-fouling paint (**mandatory in salt water**)
- Installation in a cored fiberglass hull (see page 4):
  - Hole saw for hull interior (see table below)
  - Fiberglass cloth and resin
  - or* Cylinder, wax, tape, and casting epoxy

Model (Housing)	Hull Material	Outside Hull Hole Saw Size	Cored Fiberglass Hull Hull Interior Hole Saw Size
P19-12°, P19-20°	fiberglass metal	51mm <i>or</i> 2"	60mm <i>or</i> 2-3/8"
B619-12°, B619-20° SS619-12°, SS619-20°	fiberglass wood	51mm <i>or</i> 2"	60mm <i>or</i> 2-3/8"
SS619-12°, SS619-20°	metal	57mm <i>or</i> 2-1/4"	NA
B60-12°, B60-20° SS60-12°, SS60-20° SS565-12°, SS565-20°	fiberglass wood	60mm <i>or</i> 2-3/8"	70mm <i>or</i> 2-3/4"
SS60-12°, SS60-20°	metal	70mm <i>or</i> 2-3/4"	NA
SS565-12°, SS565-20°	metal	70mm <i>or</i> 2-3/4"	NA

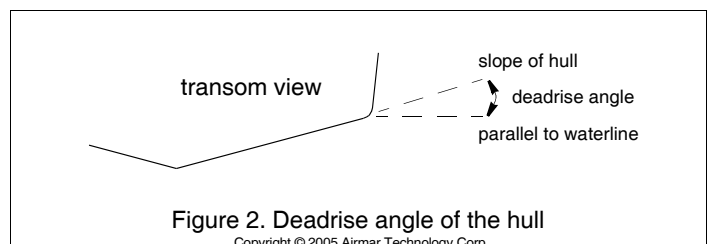

## Mounting Location

**CAUTION:** Do not mount near water intake or discharge openings or behind strakes, fittings, or other hull irregularities.

- The water flowing under the hull must be smooth with a minimum of bubbles and turbulence (especially at high speeds).
- The transducer must be continuously immersed in water.
- The transducer beam must be unobstructed by the keel or propeller shaft(s).
- Choose a location away from interference caused by power and radiation sources such as: the propeller(s) and shaft(s), other machinery, other echosounders, and other cables. The lower the noise level, the higher the echosounder gain setting that can be used.

## Hull Types (see Figure 3)

- **Displacement hull powerboats**—Locate amidships near the centerline. The starboard side of the hull where the propeller blades are moving downward is preferred.
- **Planing hull powerboats**—Mount well aft, near the centerline, and *well inboard of the first set of lifting strakes* to ensure that the transducer will be in contact with the water at high speeds. The starboard side of the hull where the propeller blades are moving downward is preferred.  
**Outboard and I/O**—Mount just forward of the engine(s).  
**Inboard**—Mount well ahead of the propeller(s) and shaft(s).  
**Stepped hull**—Mount just ahead of the first step.  
**Boat capable of speeds above 25kn (29MPH)**—Review the installation location and operating results of similar boats before proceeding.
- **Fin keel sailboats**—Mount as close as possible to the centerline and forward of the fin keel 300–600mm (1–2').
- **Full keel sailboats**—Locate amidships and away from the keel.

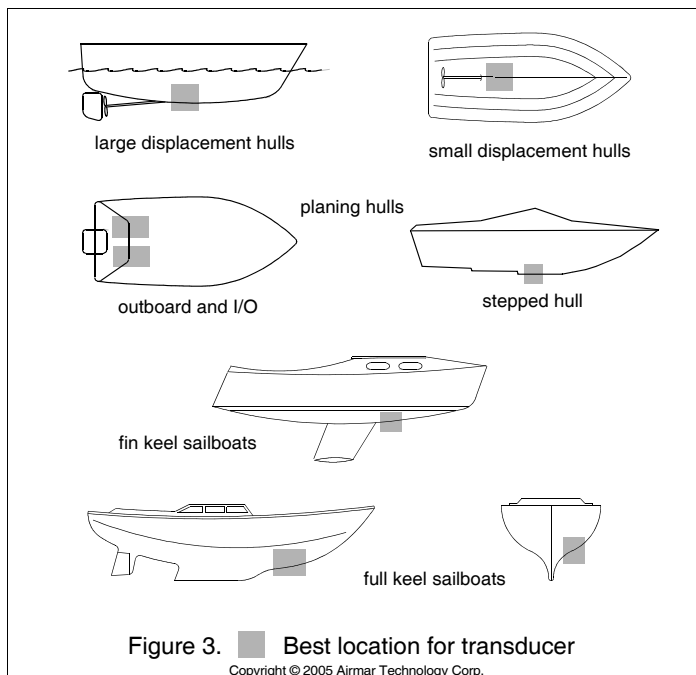

## Installation

**Cored fiberglass hull**—Follow separate instructions on page 4.

**WARNING:** Always wear safety goggles and a dust mask.

**CAUTION:** Never pull, carry, or hold the transducer by its cable; this may sever internal connections.

## Hole Drilling

1. Drill a 3 mm or 1/8" pilot hole from inside the hull. If there is a rib, strut, or other hull irregularity near the selected mounting location, drill from the outside.
2. Using the appropriate size *outside hull* hole saw, cut a hole from outside of the hull perpendicular to the hull surface (see table on page 1).  
**SS565**—Use a countersink tool to create a “seat” in the hull.
3. Sand and clean the area around the hole, inside and outside, to ensure that the sealant will adhere properly to the hull. If there is any petroleum residue inside the hull, remove it with either mild household detergent or a weak solvent (alcohol) before sanding.  
**Metal hull**—Remove all burrs with a file and sandpaper.

## Bedding

**CAUTION:** A stainless steel housing must be isolated from a metal hull to prevent electrolytic corrosion.

Apply a 2 mm (1/16") thick layer of marine sealant around the flange of the housing that contacts the hull and up the sidewall of the housing (see Figure 4 or 5). The sealant must extend 6mm (1/4") higher than the combined thickness of the hull, washer(s), and the hull nut. This will ensure there is marine sealant in the threads to seal the hull and to hold the hull nut securely in place.

**Stainless steel housing in a metal hull**—To prevent electrolytic corrosion, the stainless steel housing must be isolated from the metal hull. Slide the isolation bushing onto the housing (see Figure 5). Apply *additional* marine sealant to the surfaces of the bushing that will contact the hull, filling any cavities in and around the isolation bushing.

## Installing

**WARNING: B619 and SS619 only**—Do not use the spacer if there is insufficient space to tighten the nut or it is within 11 mm (1/2") of the top of the housing.

**WARNING: Stainless steel housing in a metal hull**—Be sure the washer contacts the hull. Do not tighten the hull nut with the washer against the isolation bushing, as the housing will not be firmly installed. If necessary, sand the isolation bushing until the washer rests against the hull.

**CAUTION:** The arrow on the top of the transducer must point toward the KEEL or centerline of the boat.

1. From outside the hull, push the housing into the mounting hole using a twisting motion to squeeze out excess sealant.
2. From inside the hull, *point the arrow on the top of the transducer (and the cable exit) toward the KEEL or centerline of the boat* (see Figure 1). This will align the angle of the element inside the transducer with the deadrise angle of your hull.
3. Slide the washer onto the housing (see Figure 4 or 5).  
**B619 and SS619**—Also slide the spacer onto the housing and rest it against the washer.

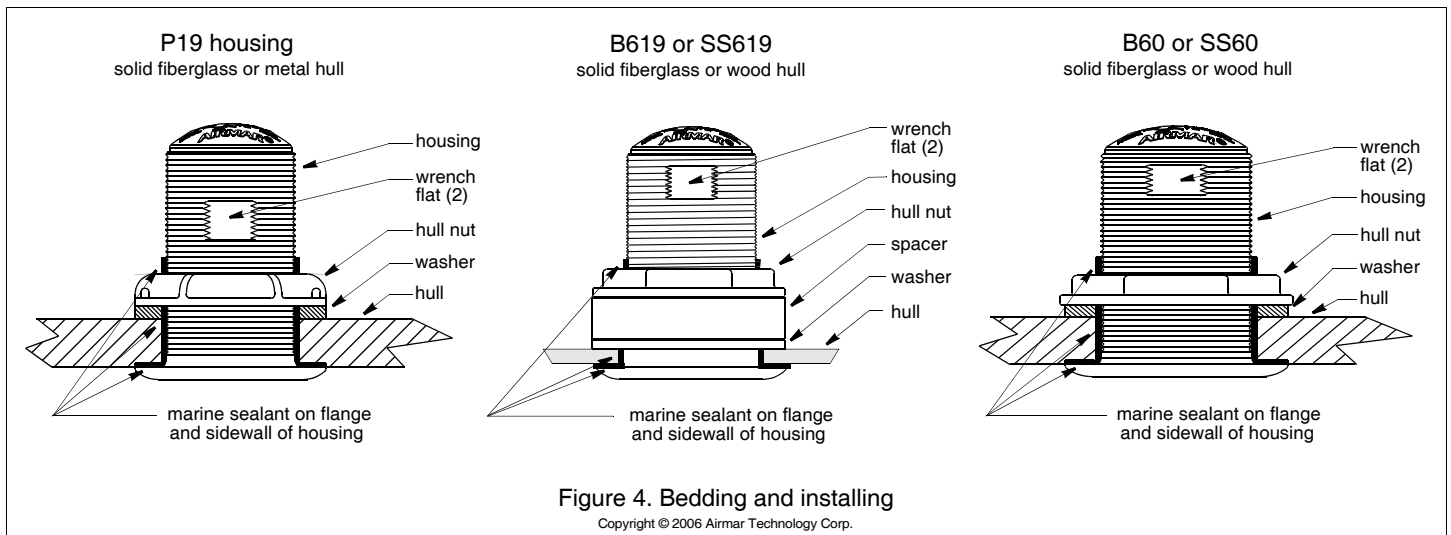

4. Screw the hull nut in place.

**Plastic housing**—Do not clamp tightly on the wrench flats to avoid possibly fracturing the housing.

**Plastic hull nut**—*Hand-tighten only*. Do not over-tighten.

**Metal hull nut**—Tighten with slip-joint pliers.

**Metal hull**—Use the spacer if there are not enough threads to tighten the hull nut against the hull.

**Cored Fiberglass Hull**—Do not over tighten, crushing the hull.

**Wood hull**—Allow the wood to swell before tightening the hull nut.

5. Remove any excess marine sealant on the outside of the hull to ensure smooth water flow over the transducer.

### Cable Routing & Connecting

**CAUTION:** If your transducer came with a connector, do not remove it to ease cable routing. If the cable must be cut and spliced, use Airmar’s splash-proof Junction Box No. 33-035 and follow the instructions provided. Removing the waterproof connector or cutting the cable, except when using a water-tight junction box, will void the sensor warranty.

1. Route the cable to the instrument, being careful not to tear the cable jacket when passing it through the bulkhead(s) and other parts of the boat. Use grommets to prevent chaffing. To reduce electrical interference, separate the transducer cable from other

electrical wiring and the engine. Coil any excess cable and secure it in place using cable ties to prevent damage.

2. Refer to the echosounder owner’s manual to connect the transducer to the instrument.

### Checking for Leaks

**WARNING:** Do not leave the boat in the water unchecked for several days.

When the boat is placed in the water, **immediately** check around the thru-hull transducer for leaks. Note that very small leaks may not be readily observed. Do not leave the boat in the water for more than 3 hours before checking it again. If there is a small leak, there may be considerable bilge water accumulation after 24 hours. If a leak is observed, repeat “Bedding” and “Installing” **immediately** (see page 2).

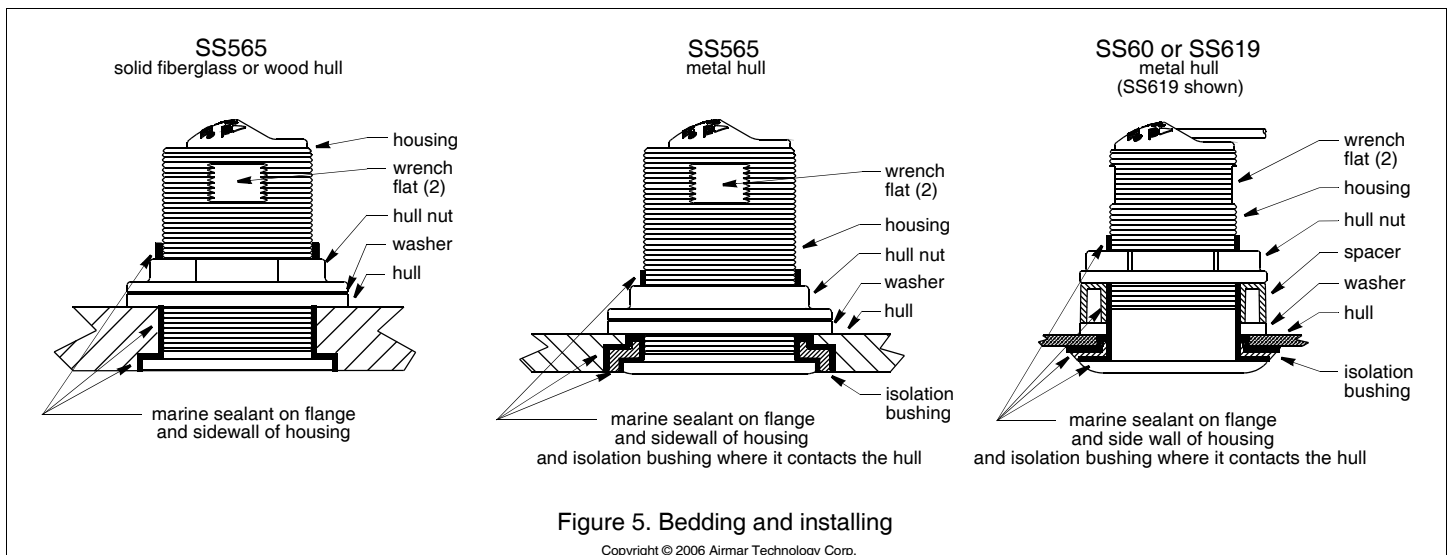

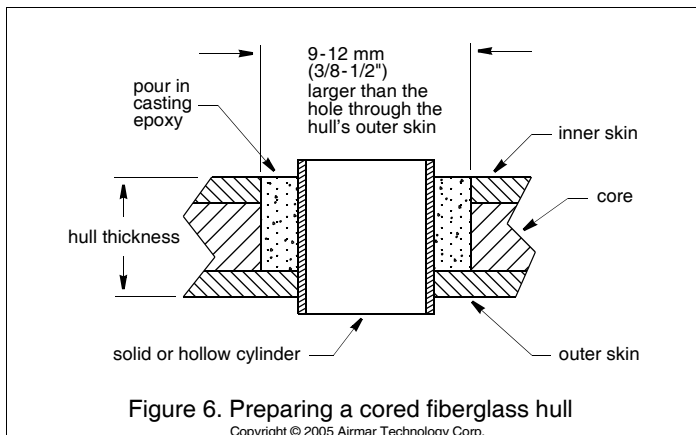

## Installation in a Cored Fiberglass Hull

The core (wood or foam) must be cut and sealed carefully. The core must be protected from water seepage, and the hull must be reinforced to prevent it from crushing under the hull nut allowing the housing to become loose.

**WARNING:** Always wear safety goggles and a dust mask.

**CAUTION:** Completely seal the hull to prevent water seepage into the core.

1. Drill a 3mm or 1/8" pilot hole from inside the hull (see Figure 6). If there is a rib, strut, or other hull irregularity near the selected mounting location, drill from the outside. (If the hole is drilled in the wrong location, drill a second hole in a better location. Apply masking tape to the outside of the hull over the incorrect hole and fill it with epoxy.)
2. Using the appropriate size *outside hull* hole saw, cut a hole from outside the hull through the *outer* skin only (see table on page 1).
3. From inside the hull, using the appropriate size *hull interior* hole saw, cut through the *inner* skin and most of the core. The core material can be very soft. Apply only light pressure to the hole saw after cutting through the *inner* skin to avoid accidentally cutting the *outer* skin.
4. Remove the plug of core material, so the *inside* of the outer skin and the inner core of the hull is fully exposed. Sand and clean the inner skin, core, and the outer skin around the hole.
5. If you are skilled with fiberglass, saturate a layer of fiberglass cloth with a suitable resin and lay it inside the hole to seal and strengthen the core. Add layers until the hole is the correct diameter.  
Alternatively, a hollow or solid cylinder of the correct diameter can be coated with wax and taped in place. Fill the gap between the cylinder and hull with casting epoxy. After the epoxy has set, remove the cylinder.
6. Sand and clean the area around the hole, inside and outside, to ensure that the marine sealant will adhere properly to the hull. If there is any petroleum residue inside the hull, remove it with either mild household detergent or a weak solvent (alcohol) before sanding.
7. Proceed with "Bedding" on page 2.

## Maintenance, Repair & Replacement

### Anti-fouling Paint

Surfaces exposed to salt water must be coated with anti-fouling paint. Use *water-based* anti-fouling paint only. Never use ketone-based anti-fouling paint, since ketones can attack many plastics possibly damaging the transducer. Apply anti-fouling paint every 6 months or at the beginning of each boating season.

### Cleaning

Aquatic growth can accumulate rapidly on the transducer's surface, reducing its performance within weeks. Clean the surface with a Scotch-Brite® scour pad and mild household detergent, being careful to avoid making scratches. If the fouling is severe, lightly wet sand it with fine grade wet/dry paper.

### Replacement Transducer & Parts

The information needed to order a replacement transducer is printed on the cable tag. Do not remove this tag. When ordering, specify the part number, date, and frequency in kHz. For convenient reference, record this information on the top of page one.

Lost, broken, and worn parts should be replaced immediately.

Model	Hull Nut	Washer	Spacer	Isolation Bushing
P19-12° P19-20°	04-004	09-452	—	—
B619-12° B619-20°	02-030	09-452	04-646-01	—
B60-12° B60-20°	02-133-01	09-813-01	—	—
SS60-12° SS60-20°	02-563-01	09-813-01	—	04-660-01
SS565-12° SS565-20°	02-563-01	09-813-01	—	04-589-01
SS619-12° SS619-20°	02-520-02	09-452	04-646-01	04-186-1

Obtain parts from your instrument manufacturer or marine dealer.

Gemeco  
(USA)  
Tel: 843.210.7000  
Fax: 843.210.7170  
email: sales@gemeco.com

Airmar EMEA  
(Europe, Middle East, Africa)  
Tel: +33.(0)2.23.52.06.48  
Fax: +33.(0)2.23.52.06.49  
email: sales@airmar-emea.com